

TYPICAL SETUP DIAGRAM FOR BLOODHOUND GAS DETECTOR SYSTEM

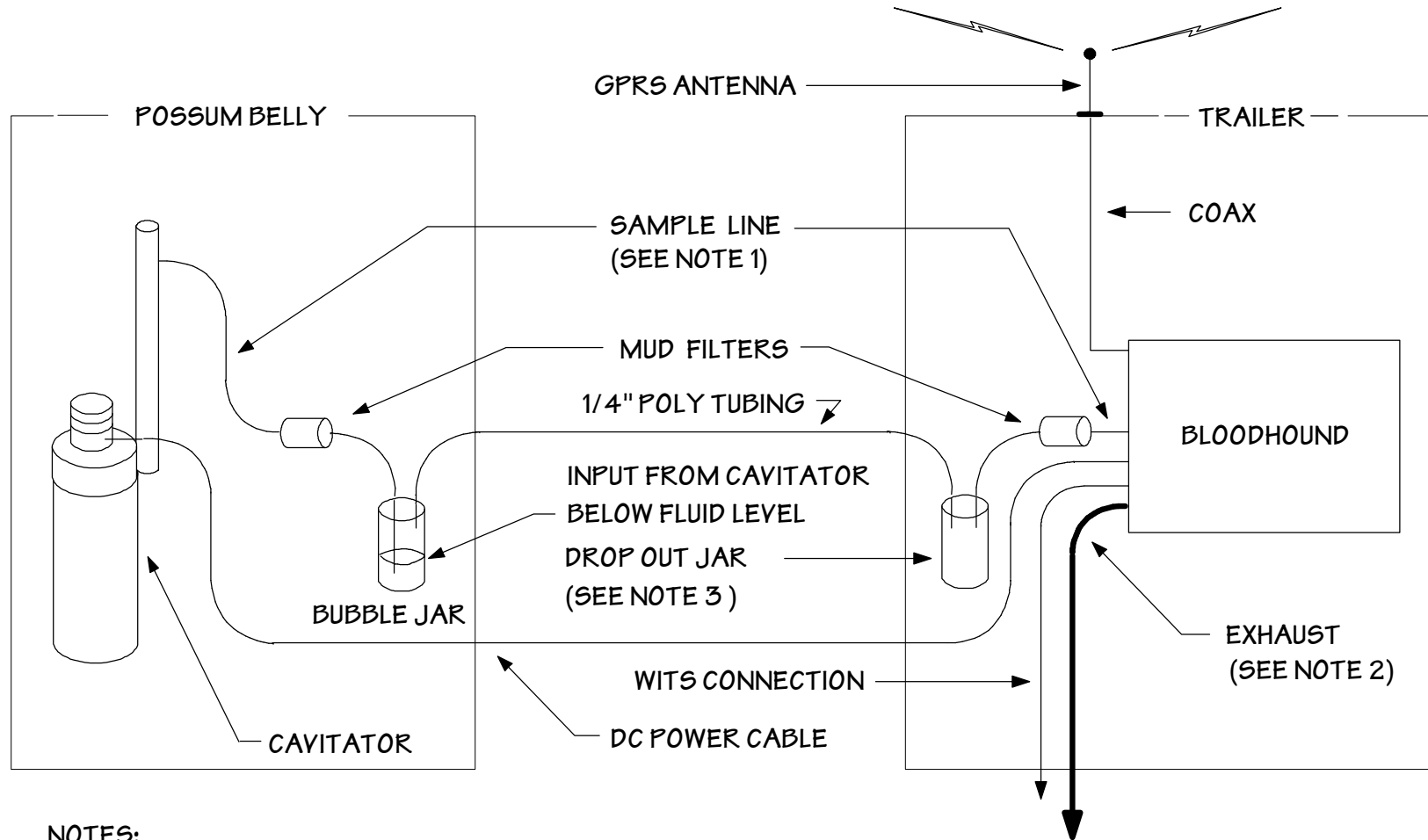

NOTES:

- 1. USE 1/4' POLYTUBING FOR SAMPLE LINE
- 2. USE 1/2' TUBING FOR EXHAUST LINE AND KEEP THIS LINE BELOW THE BOTTOM SURFACE OF THE BLOODHOUND
- 3. iBALL INSTRUMENTS SAMPLE LINE WATER EXTRACTOR CAN BE USED IN LIEU OF DROP-OUT JAR

24/7 TECH SUPPORT: 405-570-4449 or visit www.iballinstruments.com for further information